

### 2N5551 TRANSISTOR (NPN)

#### FEATURES

- General Purpose Switching Application

#### MAXIMUM RATINGS (T<sub>a</sub>=25°C unless otherwise noted)

Symbol	Parameter	Value	Unit
V <sub>CBO</sub>	Collector-Base Voltage	180	V
V <sub>CEO</sub>	Collector-Emitter Voltage	160	V
V <sub>EBO</sub>	Emitter-Base Voltage	6	V
I <sub>C</sub>	Collector Current	0.6	A
P <sub>C</sub>	Collector Power Dissipation	625	mW
R <sub>θJA</sub>	Thermal Resistance From Junction To Ambient	200	°C/W
T <sub>j</sub>	Junction Temperature	150	°C
T <sub>stg</sub>	Storage Temperature	-55~+150	°C

#### TO - 92

1. EMITTER
2. COLLECTOR
3. BASE

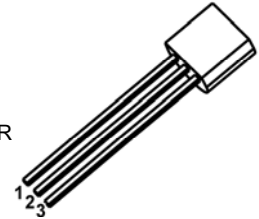

#### ELECTRICAL CHARACTERISTICS (T<sub>a</sub>=25°C unless otherwise specified)

Parameter	Symbol	Test conditions	Min	Typ	Max	Unit
Collector-base breakdown voltage	V <sub>(BR)CBO</sub>	I <sub>C</sub> =100μA, I <sub>E</sub> =0	180			V
Collector-emitter breakdown voltage	V <sub>(BR)CEO</sub> *	I <sub>C</sub> =1mA, I <sub>B</sub> =0	160			V
Emitter-base breakdown voltage	V <sub>(BR)EBO</sub>	I <sub>E</sub> =10μA, I <sub>C</sub> =0	6			V
Collector cut-off current	I <sub>CBO</sub>	V <sub>CB</sub> =120V, I <sub>E</sub> =0			50	nA
Emitter cut-off current	I <sub>EBO</sub>	V <sub>EB</sub> =4V, I <sub>C</sub> =0			50	nA
DC current gain	h <sub>FE(1)</sub>	V <sub>CE</sub> =5V, I <sub>C</sub> =1mA	80			
	h <sub>FE(2)</sub>	V <sub>CE</sub> =5V, I <sub>C</sub> =10mA	80		300	
	h <sub>FE(3)</sub>	V <sub>CE</sub> =5V, I <sub>C</sub> =50mA	50			
Collector-emitter saturation voltage	V <sub>CE(sat) (1)</sub>	I <sub>C</sub> =10mA, I <sub>B</sub> =1mA			0.15	V
	V <sub>CE(sat) (2)</sub>	I <sub>C</sub> =50mA, I <sub>B</sub> =5mA			0.2	V
Base-emitter saturation voltage	V <sub>BE (sat) (1)</sub>	I <sub>C</sub> =10mA, I <sub>B</sub> =1mA			1	V
	V <sub>BE (sat) (2)</sub>	I <sub>C</sub> =50mA, I <sub>B</sub> =5mA			1	V
Collector output capacitance	C <sub>ob</sub>	V <sub>CB</sub> =10V, I <sub>E</sub> =0, f=1MHz			6	pF
Emitter input capacitance	C <sub>ib</sub>	V <sub>BE</sub> =0.5V, I <sub>C</sub> =0, f=1MHz			20	pF
Transition frequency	f <sub>T</sub>	V <sub>CE</sub> =10V, I <sub>C</sub> =10mA, f=100MHz	100		300	MHz

\*Pulse test: pulse width ≤300μs, duty cycles ≤ 2.0%.

#### CLASSIFICATION OF h<sub>FE(2)</sub>

RANK	A	B	C
RANGE	80-100	100-150	150-200

**Typical Characteristics**

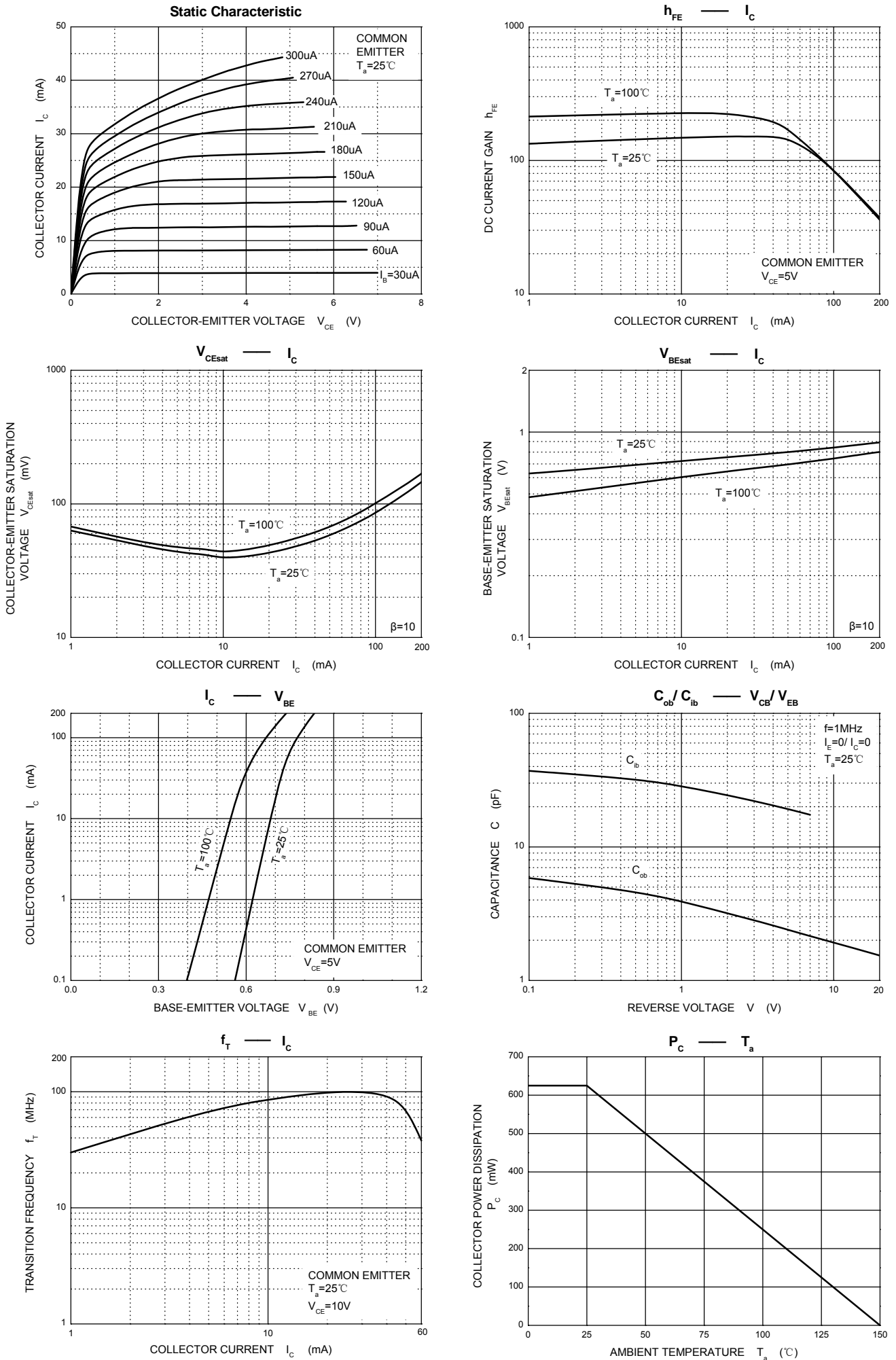

### TO-92 Package Outline Dimensions

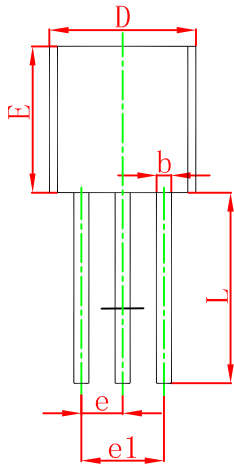
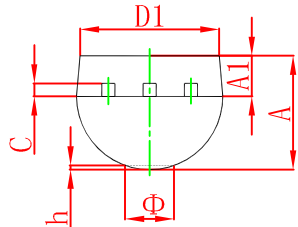

Symbol	Dimensions In Millimeters		Dimensions In Inches	
	Min	Max	Min	Max
A	3.300	3.700	0.130	0.146
A1	1.100	1.400	0.043	0.055
b	0.380	0.550	0.015	0.022
c	0.360	0.510	0.014	0.020
D	4.300	4.700	0.169	0.185
D1	3.430		0.135	
E	4.300	4.700	0.169	0.185
e	1.270 TYP		0.050 TYP	
e1	2.440	2.640	0.096	0.104
L	14.100	14.500	0.555	0.571
Φ		1.600		0.063
h	0.000	0.380	0.000	0.015

### TO-92 Suggested Pad Layout

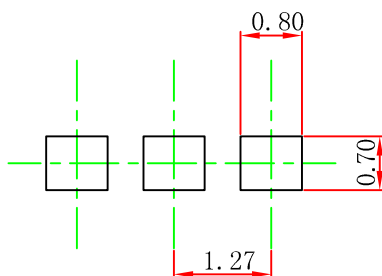

#### Note:

1. Controlling dimension: in millimeters.
2. General tolerance:  $\pm 0.05\text{mm}$ .
3. The pad layout is for reference purposes only.

**TO-92 PACKAGE TAPEING DIMENSION**

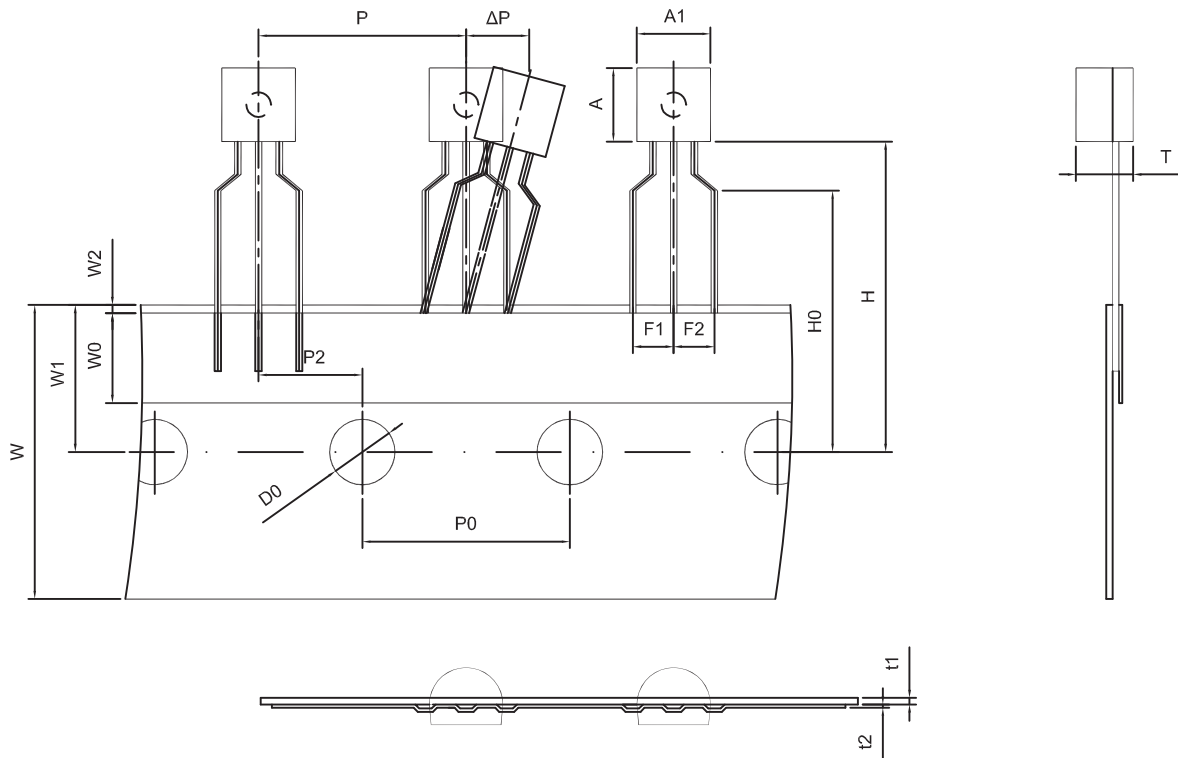

Dimensions are in millimeter								
A1	A	T	P	P0	P2	F1	F2	W
4.5	4.5	3.5	12.7	12.7	6.35	2.5	2.5	18.0
W0	W1	W2	H	H0	D0	t1	t2	ΔP
6.0	9.0	1.0 MAX.	19.0	16.0	4.0	0.4	0.2	0

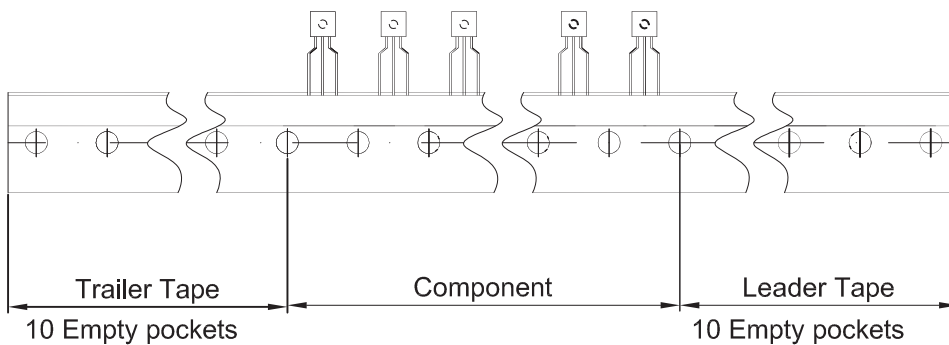

Package	Box	Box Size(mm)	Carton	Carton Size(mm)
TO-92	2000 pcs	333×162×43	20,000 pcs	350×340×250